



900-D North Macon Street | Baltimore, Maryland 21205

410-342-3820 | FAX 410-342-7324

www.newvistacorp.com



USE AND MAINTENANCE GUIDE

RT HANDHELD THREAD UNIT

Version 1.0 – February 2021



CONTENTS

| | |
|--|----------|
| CONTENTS | 2 |
| GENERAL DESCRIPTION | 3 |
| Standard Kit | |
| Customized Unit | |
| METHOD OF OPERATION | 3 |
| MODEL FEATURES | 4 |
| Adjustable Torque Clutch | |
| Type FP Tool Chuck and Tool Adapters | |
| Rocker Trigger | |
| Two Speed Gear Drive | |
| Battery Powered | |
| Tool Adapter Overview | 5 |
| Type FP Chuck and Compliant Tool Adapters | |
| FP Tool Adapter for Tapered Shank Tools | |
| FP Tool Adapter for Reversible Tools | |
| FP Tool Adapter for Straight Shank Tools | |
| FP Socket Adapter Tool | |
| Type J Chuck and Tool Adapters | |
| J Tool Adapter for Ring Tools for external threads | |
| J Tool Adapter for BH Gages | |
| J to FP Adapter | |
| Tool Changeover | |
| To Engage a Tool Adapter | |
| To Remove a Tool Adapter | |
| Stop Collars for Depth Verification | |
| GAGE RECOMMENDATIONS | 9 |
| OPERATING INSTRUCTIONS | 9 |
| Getting Started | |
| TORQUE ADJUSTMENT | 9 |
| Procedure | |



GENERAL DESCRIPTION

The RT Thread Unit is a cordless Thread Verification Unit for mechanically checking threads or light thread chasing.

Standard Kit

The RT Thread Unit can be purchased as a standard Kit from New Vista directly or through our online store: <https://www.newvistacorp.com/shop>. The Kit comes with everything needed to start verifying threads using standard taper shank gages. Each Kit includes the following:

- One RT Thread Unit equipped with a type FP chuck
- Three taper shank gage tool adapters (for handle sizes no. 0, 1, and 2)
- One torque adjustment tool (a spanner wrench for 1-1/2" diameter circle with a 7/32" pin)
- Two 14.4V rechargeable lithium-ion batteries
- One battery charger



Figure 1
RT Kit Contents

Customized Unit

The RT Thread Unit can be customized to meet a wide variety of applications including, but not limited to, left-hand threads, external threads, restricted-access situations, large threads, and unique gaging needs. Please contact us to discuss your application.

METHOD OF OPERATION

To operate the unit, place the gage member or cleanout tool at the start of the thread. Align the axis of the tool with the axis of the hole, push the unit firmly and pull the rocker trigger in the forward direction. To reverse out of the threaded hole push the rocker trigger in the reverse direction.

MODEL FEATURES

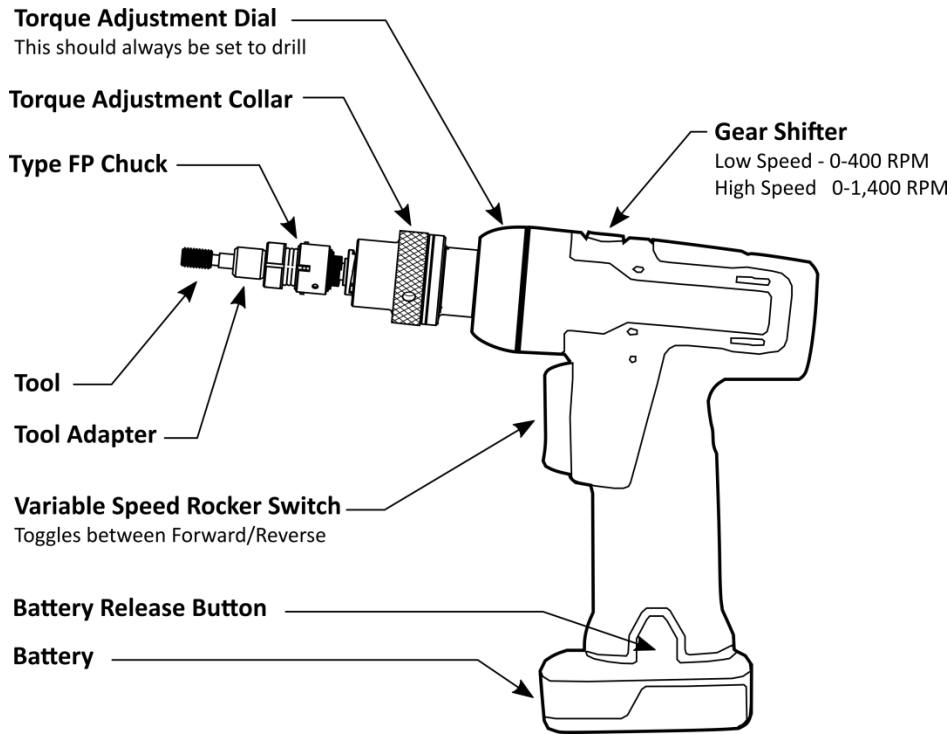

Figure 2

Adjustable Torque Clutch

The RT Thread Unit comes with a 62020AC New Vista clutch. This sensitive, patented clutch allows the thread tool to stop harmlessly if there is an obstruction in the thread. The torque in reverse is always at maximum power to minimize the chance of a tool becoming jammed in a hole. The forward torque is easily adjustable.

Type FP Tool Chuck and Tool Adapters

The FP chuck, along with the matching FP Tool Adapters, allows for tool changes that take less than 4 seconds. These compliant tool adapters prevent jamming from misalignment and will follow the existing thread. FP Tool Adapters are available for three of the most common tool shank styles: taper, straight, and reversible (fully-threaded).

Custom tool adapters are available to accommodate ring gages or dies for external threads, and our type BH tool adapters for larger threads sizes or especially deep threads.

Rocker Trigger

The variable-speed rocker trigger gives the user full control over speed and direction, making it easy to enter a hole and switch to reverse.



Two Speed Gear Drive

Two speeds to accommodate your needs:

- Low speed: 0 to 400 RPM
(Typically used for the largest thread sizes or where more torque is required.)
- High speed: 0 to 1,400 RPM
(Default setting for most applications.)

Battery Powered

The RT is powered by a 14.4V Lithium-ion battery that is easily sourced from Snap-on Tools: <https://shop.snapon.com>, Item#: CTB8174.

Tool Adapter Overview

Type FP Chuck and Compliant Tool Adapters

This is the standard chuck included in the RT Kit. It allows for tools to be changed in seconds. All Type FP Tool Adapters provide compliance. Custom sizes are available for special order. Contact us with your requirements for application assistance.

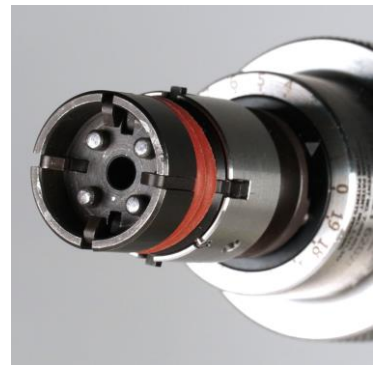

Figure 3
FP Type Chuck

FP Tool Adapter for Tapered Shank Tools

We offer five sizes of tool adapters for tapered shank gages/tools.

Taper Size 00

Metric Threads (M3, M3.5)
ANSI Threads (#4, #5, #6)

Taper Size 0

Metric Threads (M4, M5)
ANSI Threads (#8, #10, #12)

Taper Size 1

Metric Threads (M6, M7, M8, M9)
ANSI Threads (1/4", 5/16")

Taper Size 2

Metric Threads (M10, M11, M12)
ANSI Threads (3/8", 7/16", 1/2")

Taper Size 3

Metric Threads (M14, M15, M16, M17, M18, M20)
ANSI Threads (9/16", 5/8", 3/4")



Figure 4
Tapered Shank Gage shown with an FP Tool Adapter for tapered shank gages.

FP Tool Adapter for Reversible Tools



Figure 5

Reversible (Full-Threaded) Gage shown with an FP Tool Adapter for Reversible Gages.

Reversible (Fully-Threaded) tool adapters are available in the following sizes:

Metric Threads: (M5, M6, M8, M10, M12)

ANSI Threads: (#12, 1/4", 5/16", 3/8", 7/16", 1/2")

Other sizes are available upon request.

FP Tool Adapter for Straight Shank Tools



Figure 6

Straight-Shank Gage shown with an FP Tool Adapter for Straight-Shank Gages.

Tool adapters to accommodate straight shank tools are available in 3/16" and 1/4" sizes. Other sizes are available upon request.

FP Socket Adapter Tool



Figure 7

FP Socket Adapter Tool

The FP Socket Adapter Tool attaches to a standard 3/8" Socket wrench. It is useful for extracting a gage that has become jammed in a thread. This may happen if the clutch torque is set at too high a value for the size of thread.

Type J Chuck and Tool Adapters

This is a custom chuck that accommodates gages for large threads, external threads, or deep threads. Type J Chucks and Tool adapters are custom ordered and are not available in the standard kit. Please contact us for application assistance.



Figure 8

Type J Chuck End

**J Tool Adapter for Ring Tools
for external threads**



Figure 9

These compliant tool adapters can accommodate ring gages for thread verification and dies for light chasing of threads.

J Tool Adapter for BH Gages



Figure 10

Type BH Gages allow for compliance in larger size gages or in especially deep threads.

J to FP Adapter



Figure 11

This adapter allows standard type FP tool adapters to be used on an RT equipped with a Type J chuck.

Tool Changeover

Both Type FP and Type J tool adapters are designed to be easily changed.

To Engage a Tool Adapter

Align shaft of chuck with the hole in the center of the toolholder then push the tool adapter into the chuck. Twist the tool adapter in either direction while you are pushing. This helps the drive pins align with the slots in the toolholder

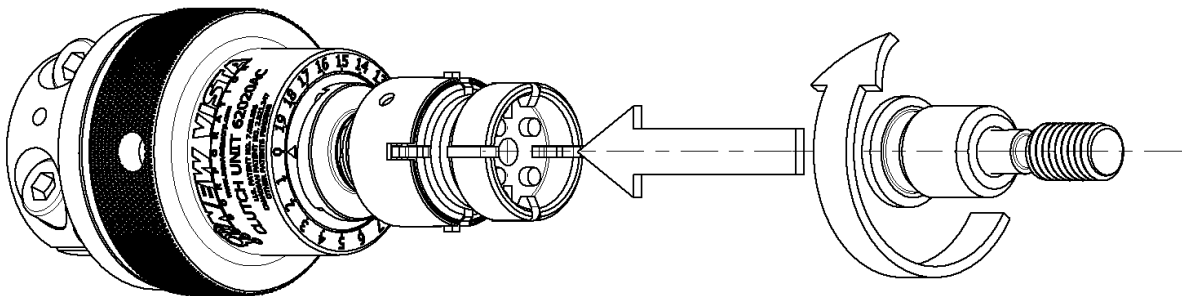

Figure 12

Twist the tool adapter while inserting it into the chuck.

To Remove a Tool Adapter

Pull the tool adapter away from the chuck along the chuck's axis of rotation.

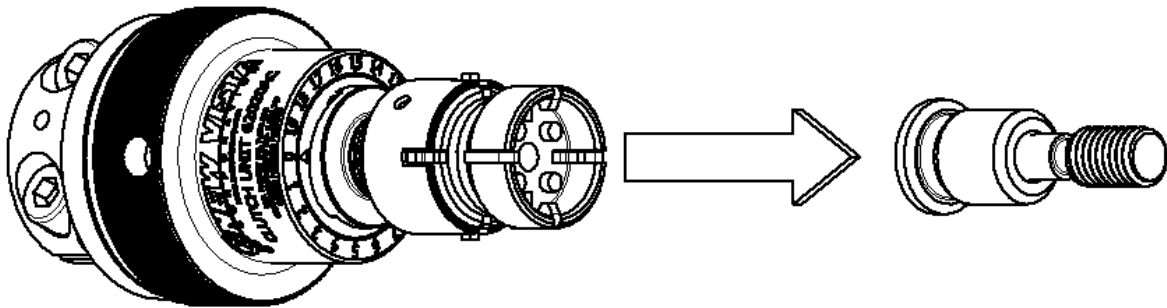

Figure 13

Pull the tool adapter along the chuck's axis.

Stop Collars for Depth Verification

Most of the aforementioned tools can be fitted with a stop collar to verify that the desired depth has been attained. To adjust the stop collar, simply loosen its screw(s), reposition the collar, and retighten the screw(s). If the tool has a non-threaded pilot, be sure to take it into account when setting the depth.

Stop collars are available in many styles. We generally recommend the split, clamping-style collars. Collars are available from Misumi with a urethane damper on one side that helps to prevent marring of the part surface.

Stop collars (shaft collars) are easily obtained from many sources. Some recommended sources are:

- McMaster-Carr:
<https://www.mcmaster.com/stop-collars/clamping-shaft-collars-9>
- Misumi:
<https://us.misumi-ec.com>
- Fastenal:
<https://www.fastenal.com>
- Grainger:
<https://www.grainger.com>



Figure 14

GO Gage with Stop Collar

GAGE RECOMMENDATIONS

The RT Thread Unit can be used with standard off-the-shelf thread gages and tools.

For typical GO and NO GO thread verification applications we recommend grinding a 45° chamfer that is equal to 50% of the gage's major diameter on the end of the gage. This should remove the cleanout groove on the end of the gage and allow for easier thread engagement.

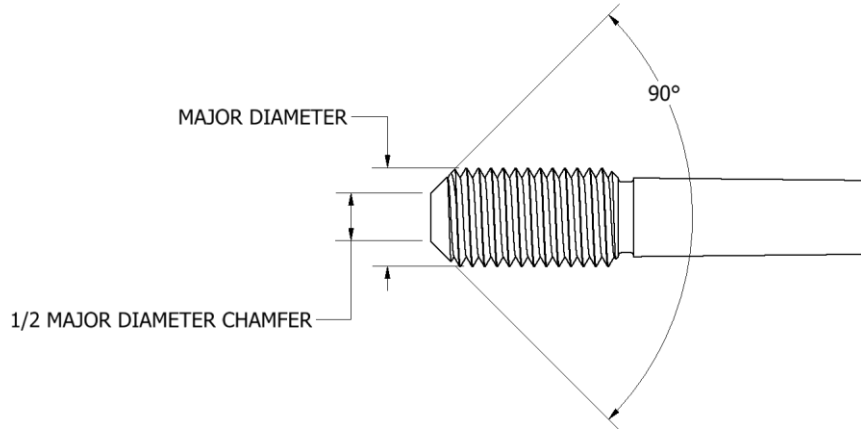

Figure 15
Gage Chamfering Recommendations

OPERATING INSTRUCTIONS

Getting Started

1. Adjust the torque as necessary.
2. Attach the proper thread tool and tool adapter.
3. Adjust the stop collar to proper depth if you are using one.
4. Use the RT Thread unit as you would a handheld screwdriver.

TORQUE ADJUSTMENT

The torque adjustment collar, located behind the tool adapter, changes the torque setting. This controls the amount of torque required to make the internal mechanism slip in the clockwise/forward direction (for right hand threads).

The torque should be adjusted to a level that simulates the torque an operator would output with a hand gage. You can contact New Vista for recommended torque settings by thread size. In the counter clockwise/reverse direction (for right hand threads), the unit will apply the full torque available from the motor to unscrew the tool. This ensures that a tool that has stalled during the cycle can be unscrewed in reverse.



The torque collar is designed to turn stiffly so that a preset torque level it will not change. In most cases adjustment will require a spanner wrench (included).

Note:

For standard RT Kit Units this setting has not been preset at the factory and should be set to a torque appropriate for your application.

For custom units this setting is adjusted at the factory and should be tested on-site before performing any adjustments.

Measuring the torque setting is accomplished by locking two nuts on the thread gage member and using a torque wrench to measure the stall torque of the clutch. The torque should be adjusted in small increments and tested to achieve the desired value.

Warning:

We highly recommend that you remove the battery from the unit while setting the torque.

Do not run the tool in the reverse direction while performing this procedure. The clutch only slips in one direction. The full torque of the unit will be exerted if the unit is jogged in the reverse.

Procedure

1. Use a small torque wrench with a range of at least 0-45 in-lbs. (0-5N-m).
2. Remove the battery from the unit.
3. Lock two nuts on the thread gage. Install a matching socket on the torque wrench.
4. With one hand hold the torque wrench with the socket holding the nuts and measure the torque setting by turning the wrench in the forward (clockwise for right-hand threads) direction. The actual torque is read while the clutch is slipping.
5. To adjust the clutch setting, turn the knob to the required setting. Turning the knob clockwise increases the amount of torque needed. If the collar is too hard to turn by hand use the included spanner wrench.
6. Remove the nuts from the gage.

Torque Adjustment Collar
Use included spanner wrench to

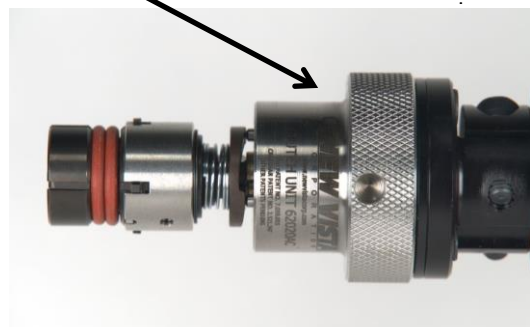



This page intentionally left blank